

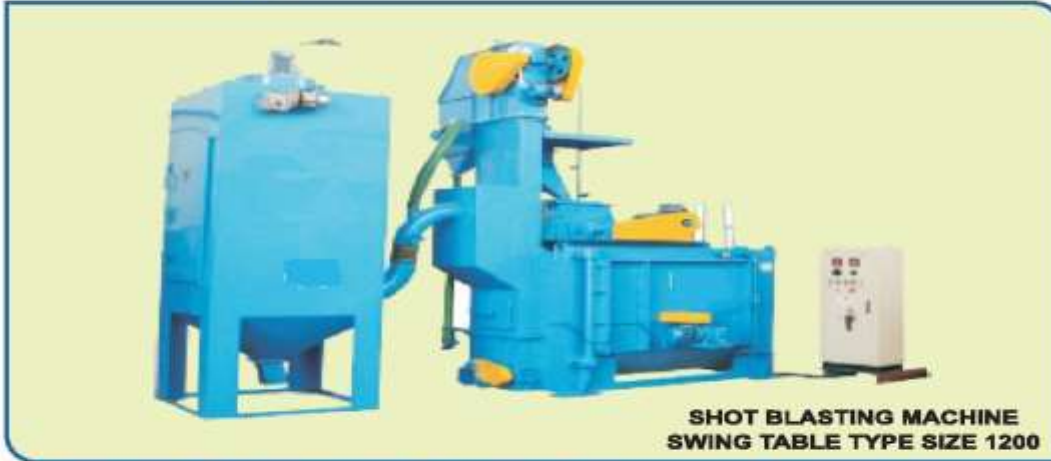

Swing Table Type Airless Shot Blasting Machine

SMOOTH COMPLEXION FOR YOUR METAL SURFACE



**SHOT BLASTING MACHINE
SWING TABLE TYPE SIZE 1200**

APPLICATIONS :

- Aesthetic Finishing of Die Casting of Aluminium, Zinc & Alloy Steels.
- Desanding & Descaling of Casting & Forgings.
- Cleaning of Castings & Forgings.
- Preparation of Surface for Protective coating.
- Shot Peening of heavily stressed components.
- Removal of heat treated scales.

SPECIAL FEATURES:

These machines are sturdy, rugged and proven across a wide variety of working conditions. They have been designed to carry out the multifarious jobs of cleaning and peening in faster time and of a better quality than all other makes of the machine. The latest design of blast wheel is incorporated, in order, also to keep the maintenance costs significantly low. The rubber conveyor belt is rugged and given long life. Hence the machine is most economical in operation.

Dust collector options are available i.e Fabric, Cartridge type, as per the choice, The machine is available with various additional optional features like second door, rotary screen separator, abrasive replenisher, Program-logic Control System, Time Control, Electronic Brake system for blast wheel, sound reducer etc. Please select the optional features as per your choice.

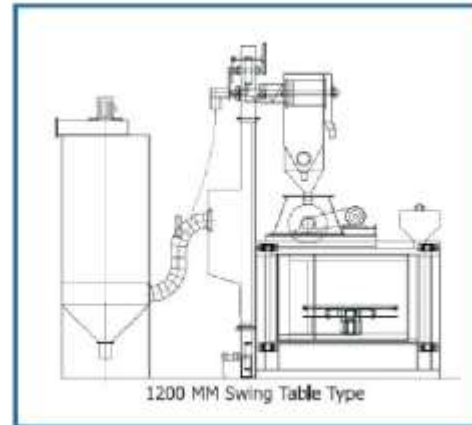

TECHNICAL SPECIFICATION FOR AIRLESS SHOT BLASTING MACHINE SWING TABLE TYPE

S.No.	PARTICULARS	ASBMF-750		ASBMF-1200		ASBMF-1800		ASBMF-2440	
1.	Size of Blast Wheel	12.5" X 2.5"		19.5" X 2.5"		19.5" X 2.5"		19.5" X 2.5"	
2.	No. of Blast Wheel	One		One		One		One	
3.	Power of Blast Wheel	7.5 H.P.		15 H.P.		25 H.P.		20 H.P.	
4.	Shots Flow Rate (Kg./Hour)	6500		9000		15000		12000	
5.	Shot Velocity (Mtr./Second)	40 - 50		65 - 75		65 - 75		65 - 75	
6.	No. of Swing Table	One		One		One		One	
7.	Diameter of Swing Table	750mm (30")		1200mm (48")		1800mm (72")		1440mm (96")	
8.	Maximum Load on Table	350 kg.		750 kg.		2500 kg.		4500 kg.	
9.	Loading Height (mm)	1125		950		950		1200	
10.	Maximum job Height (mm)	300		600		1000		1060	
11.	Type of Dust Collector	Fabric Bag		Fabric Bag		Fabric Bag		Fabric Bag	
12.	Dust Collector Capacity (CFM)	1200		2000		3000		4500	
13.	Shaking of Bags	Manual		Mechanical		Mechanical		Mechanical	
14.	Total H.P. Required	12		23		36		56	
15.	Dimension of Machine with Dust Collector:	Single Door	Double Door	Single Door	Double Door	Single Door	Double Door	Single Door	Double Door
	Length (mm)	2700	4050	4500	6350	6400	9400	10500	13500
	Width (mm)	3450	3450	4300	4300	5900	5900	6500	6500
	Height (mm)	4100	4100	4300	4300	5300	5300	5750	5750

Note : Above specifications are approximate and are subject to change without notice.



NATIONAL ENTERPRISES

MANUFACTURERS OF : Industrial Blast Rooms, Airless & Air Operated Abrasive Blasting Machines, Shot Peening Plants, Industrial Dust Collectors, Painting Equipments & Booths



CORPORATE & SALES OFFICE : 12/2, Main Road, Opp. Lumax Automotive Systems Ltd., Nr. Sec-37 Modh, Faridabad-121003.

Mob. : +91 8527923333, +91 9718383333 E-mail :- sales@nationalenterprises.org ; info@nationalenterprises.org

Registered Address: A-1708, 1st Floor, Green Fields, Faridabad - 121003, (Haryana) Tel/Fax No. : 0129-4083366/4086633

Manufacturing Works Jodhpur: Khasra No.41/5, Sunaj Nagar, Guda Road, Jhalamand, Jodhpur-342013

E-mail: works@nationalenterprises.org ; jodhpur@nationalenterprises.org

Regional Office Pune: 4, Survey No. 81/2, Dangal Indl Estate, NDA Road, Near Agrawal Godown, Shivane, Pune - 411023.

E-mail: pune@nationalenterprises.org

Bangalore Branch Office: 133, Arundodaya, 4th Cross, I N Block Rajaji Nagar, Bangalore - 560010.

Regional Office Kolkata: Mobile +91 8527153333

Website: www.nationalenterprises.org; www.shotblastingpainting.in

Our Sales & Service Network - ♦ Faridabad ♦ Pune ♦ Jodhpur ♦ Ahmedabad ♦ Ludhiana ♦ Kolkata ♦ Chennai



ISO 9001:2008